

Installation Instruction DIREKT 150 Gate Closer with Eyelets and Ball Bearings

1. Which kind of hinge?

Determine starting point

Dimensions in mm

Fixing brackets

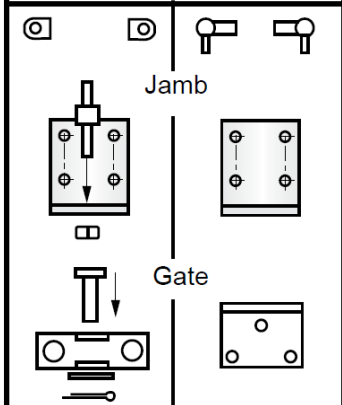
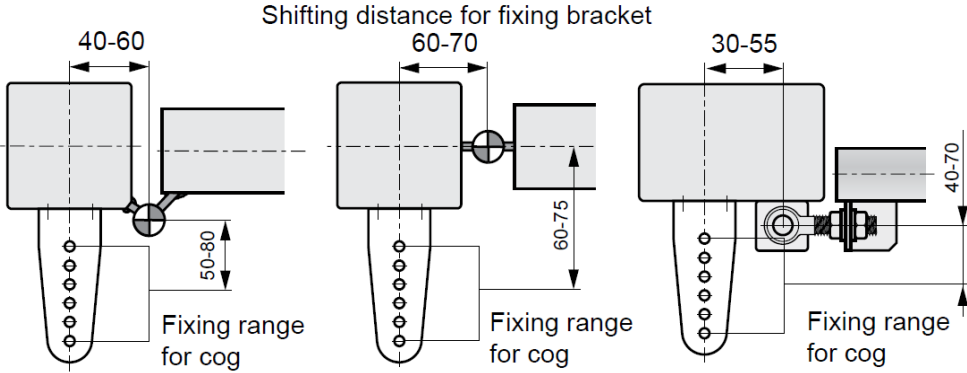

2. Provisional installation of the brackets

3. Control of dimensions when the gate is OPEN

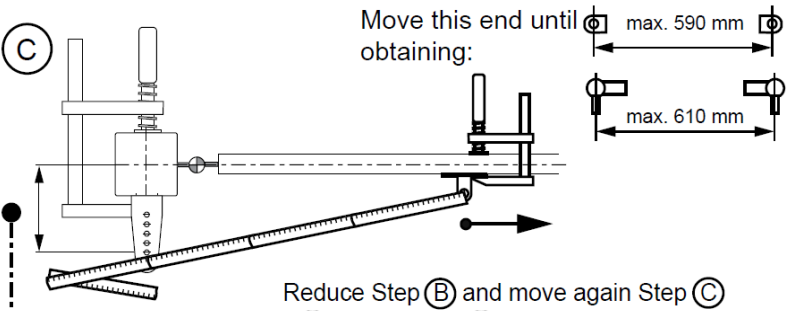
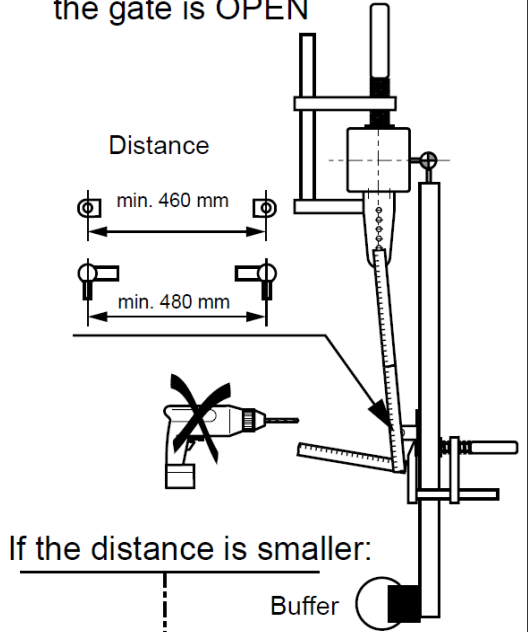
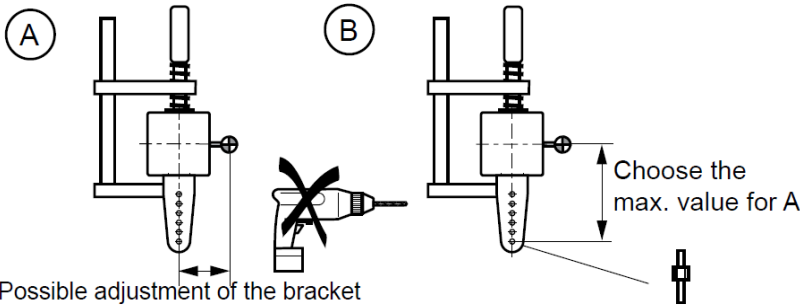

4. Assemble the bracket and align it

5. Fixing

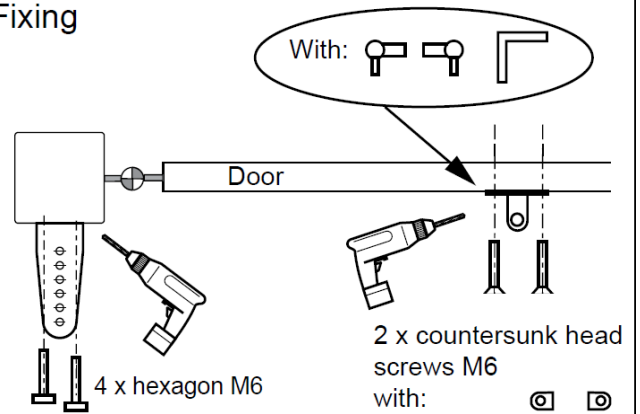
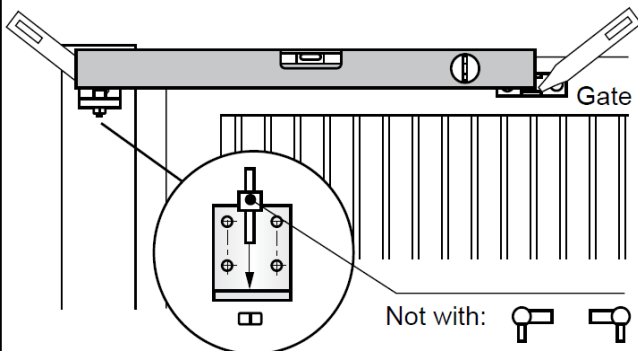

6. Blocking and compressing

Steady eyelet

Turn knurl clockwise until the end.

Compress the door closer min. 50 mm.

7. Fix the DIREKT and adjust the closing speed

Always fix this end at the jamb.

Bearing bush $\varnothing 28$

V -

V +

End with adjustment always on door!

8. Provide a mechanical stop in position OPEN, otherwise

Distance X

min. 460 mm

min. 480 mm

Mechanical stop

Special applications:

Use on both sides if smaller than 65

Door OPEN

Wall

Jamb

Door OPEN

larger than 50

Adjust the pressure, only when absolutely necessary!

O-ring

Bearing bush

WG slightly glued!

Protective glasses

Gloves

SOFTLY 2-4 times, then fix DIREKT and repeat if necessary.

Max. 100 grams

Mixture of oil and gas

Adjustment / Maintenance

V- "summer"

V+ "winter"

according to season

Grease

1 - 2 x per year

Refix

1 x per year

Last check:
 Mechanical stop in position OPEN? End with adjustment screw on door? Screws fixed? Moving parts greased? Customer instructed?